

Tornado



The model name and serial number should always be provided when ordering spare parts or during queries per telephone or written correspondence:

Serial number of the machine:

.....

Machine model:

.....

Design Policy and Copyright

® and ™ are trademarks belonging to the Arjo group of companies.

© Arjo 2023.

As our policy is one of continuous improvement, we reserve the right to modify designs without prior notice. The content of this publication may not be copied either whole or in part without the consent of Arjo.

Contents

PREFACE.....	5
1 SAFETY PRECAUTIONS.....	6
1.1 General safety regulations.....	7
1.2 Isolator switch.....	8
1.3 In an emergency.....	8
1.4 Product liability.....	8
1.5 Attention symbols.....	8
2 INSTALLATION OF MACHINE.....	9
2.1 General.....	9
2.1.1 Make sure assembly and installation work is carried out.....	9
2.1.2 Installation order.....	9
2.1.3 Installation alternatives.....	9
2.2 Unpacking.....	10
2.3 Scale drawings.....	11
2.3.1 Freestanding model placed next to wall.....	11
2.3.2 Freestanding model wall-mounted.....	12
2.3.3 Under-bench model.....	13
2.4 Assembly.....	14
2.4.1 Freestanding model placed next to wall.....	14
2.4.2 Freestanding model wall-mounted.....	15
2.4.3 Under-bench model.....	16
2.4.4 Trap and ventilator.....	16
2.4.5 Sealing requirements for under-bench model.....	17
2.5 Water connections.....	17
2.5.1 General requirements.....	17
2.5.2 Requirements for KIWA certified installations.....	18
2.5.3 Requirements for backflow prevention installations.....	18
2.5.4 Connect water.....	18
2.6 Electrical connections.....	19
2.6.1 Positioning the transformer.....	19
2.6.2 Connect electricity.....	19
2.6.3 Coupling alternative.....	20
3 INSTALLATION OF OPTIONS.....	22
3.1 Printer (FD1800/1810).....	22
3.1.1 Connection.....	22
3.1.2 Configuration.....	23
3.1.3 Test and verification.....	23
4 INSPECTING THE INSTALLATION.....	24
4.1 When the work is complete, check that.....	24
4.2 Function check.....	25
4.3 Control panel.....	26
4.3.1 FD1800/FD1805.....	26
4.3.2 FD1810.....	26

5	TECHNICAL DATA.....	27
5.1	Connections.....	27
5.2	Environmental requirements.....	27
5.3	Water consumption.....	27
5.4	Exterior dimensions.....	27
5.5	Weight.....	27
5.6	Protection class.....	28
5.7	Sound level.....	28
	5.7.1 Estimated sound level.....	28
	5.7.2 Example.....	29
6	WATER QUALITY.....	30
6.1	Requirements.....	30
6.2	Main factors.....	30
6.3	Recommendation.....	30
6.4	Local standard.....	30
6.5	Local standard, typical specification.....	31
7	END OF LIFE DISPOSAL.....	32

PREFACE

The user manual describes the design and operation of the machine and the maintenance for which the user is responsible. The installation manual describes the machine's installation. The technical manual describes necessary information for operators and maintenance personnel. The information in the manual must be complied with to ensure safe and error-free operation.



Read the manual before use.

Users must read through the manual before using the machine for the first time, as well as familiarizing themselves with the operation of the machine and its safety instructions. Operators and maintenance personnel must have completed training through the marketing organization of Arjo.

The information in this manual describes the machine as dispatched from Arjo. There may be differences due to customization for customers or countries.

The machine is accompanied by the following documentation:

- User manual
- Installation manual
- Quick guide

The following documentation shall be provided by the sales company to the end-user on request:

- Technical manual
- Spare parts list

The accompanying Quick guide must be hung up and clearly visible in the installation area.

Arjo reserves the right to change the specification and design without prior notice. The information in this manual was up-to-date on the date that the manual was issued.

1 SAFETY PRECAUTIONS

Operators and maintenance personnel must undergo safety training for the machine. All personnel who handle chemicals for washing and disinfection must understand the washing process, possible health hazards and ways of detecting leaks of toxic chemicals.

Operators and maintenance personnel must undergo regular training in the operation and maintenance of the equipment. There must be a documented list of personnel who have been trained to use the machine. Trained personnel must be tested to verify the training program.

This machine has been designed with a number of built-in safety devices.

To avoid injury, it is highly important not to bypass these safety devices.

1.1 General safety regulations



Do not wash down or hose down the machine with water.

- Read the user manual thoroughly before use
- The equipment must only be used by personnel who know about it and are trained to use it. Personnel must also receive regular training on this equipment. Documents which state the names of the personnel who took part in and understood the training must be archived.
- Take care when handling the chemical agent used in the machine. Read the details on the container or contact the manufacturer for measures if:
 - if the agent comes into contact with the operator's eyes or skin or if the vapors are breathed in, etc.
 - about storing the detergent and disposing of empty containers.
- Never use the flusher-disinfector if you are not sure how to operate it.
- The machine must be kept clean if it is to work properly.
- The electric power must be switched off before the machine cabinet is opened. (The machine cabinet contains electrical components).
- Make sure that there is always detergent in the bottles. This is important both for the operation of the machine and for keeping the washing chamber free from staining.
- Always use the equipment in accordance with the local regulations.
- Always connect the equipment via an RCD (residual current device).
- Always use a grounded power supply for the flusher-disinfector.
- If the items have not cooled down after cleaning, be sure to handle them with care, to avoid burns.
- Before starting, check the waste outlet at the bottom of the flushing chamber for blockages. This will ensure that the machine works properly.
- Do not place items that are sensitive to heat or moisture on top of the flusher-disinfector.
- Spare parts must only be obtained from Arjo's sales companies.

1.2 Isolator switch

The machine must always be equipped with a separate isolator switch in the feed power supply. The isolator switch must be easily accessible on a wall close to the machine. The external electrical isolator switch must be marked “I” and “O” to identify the position of the switch.

1.3 In an emergency

- Switch off the main switch.
- Close shutoff valves in the water and any steam supply lines.

1.4 Product liability

CE marking indicating conformity with European Community harmonised legislation.

Any modification or incorrect use of the equipment without the approval of Arjo negates Arjo's product liability.

 **CE marking indicating conformity with European Community harmonised legislation**
2797 **Figures indicate Notified Body supervision.**

1.5 Attention symbols

There are warnings, instructions, and advice in this manual that require extra attention. The symbols and designs used are:



Risk of injuries or machine damage.

2 INSTALLATION OF MACHINE

2.1 General

2.1.1 Make sure assembly and installation work is carried out



WARNING!

To avoid the risk of back injury, this equipment should be assembled and installed by at least two people.

- by qualified personnel.
- in accordance with current local regulations and rules.
- for indoor installation only.
- not to be installed in wet locations.
- in accordance with AS/NZS 3500.1 and AS/NZS 3500.2 including the installation of any non-integral backflow prevention device.

2.1.2 Installation order

Carry out the installation in the following order:

1. Unpacking
2. Assembly
3. Connecting water
4. Connecting electric power
5. Installation inspection

2.1.3 Installation alternatives

The following installation alternatives exist:

Type (Designation)	Possible positioning
Free-standing model (FD1800, FD1810)	Placed on the floor next to the wall or attached to a wall.
Under-bench model (FD1805)	Under a bench or similar.

2.2 Unpacking

Note!

Before installing make sure the flusher-disinfector has not been damaged in transit.

The following items must accompany the flusher-disinfector when it is delivered:

- Two cabinet keys
- One folder containing documentation

The flusher-disinfector is supplied securely bolted to a pallet.

1. Remove the packaging.
2. Move the flusher- disinfector as close to the installation position as possible, when still secure to the pallet using mechanical means.
3. Remove the bolts securing the flusher disinfector to the pallet.

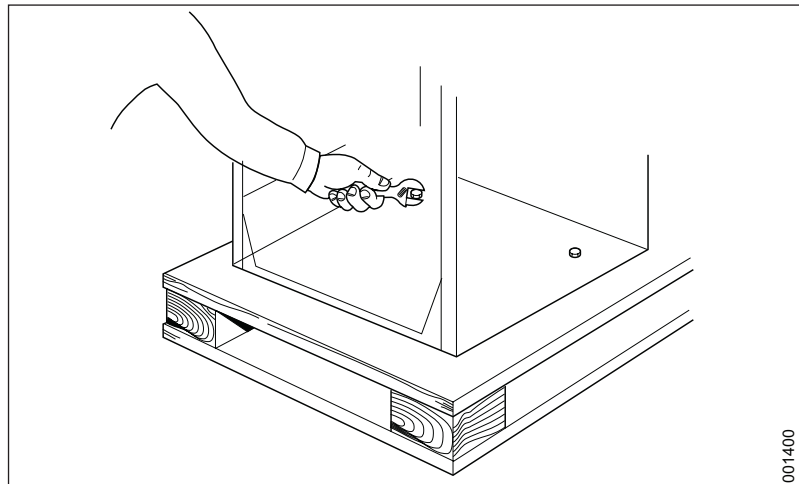

Figure 1. Removal of anchoring bolts

4. Assess the flusher-disinfector for lifting from the pallet. Use at least two persons to lift the flusher-disinfector to the floor or to a low level wheeled trolley to aid movements to the final position.

2.3 Scale drawings

2.3.1 Freestanding model placed next to wall

Scale drawings apply to the FD1800 and FD1810 models.

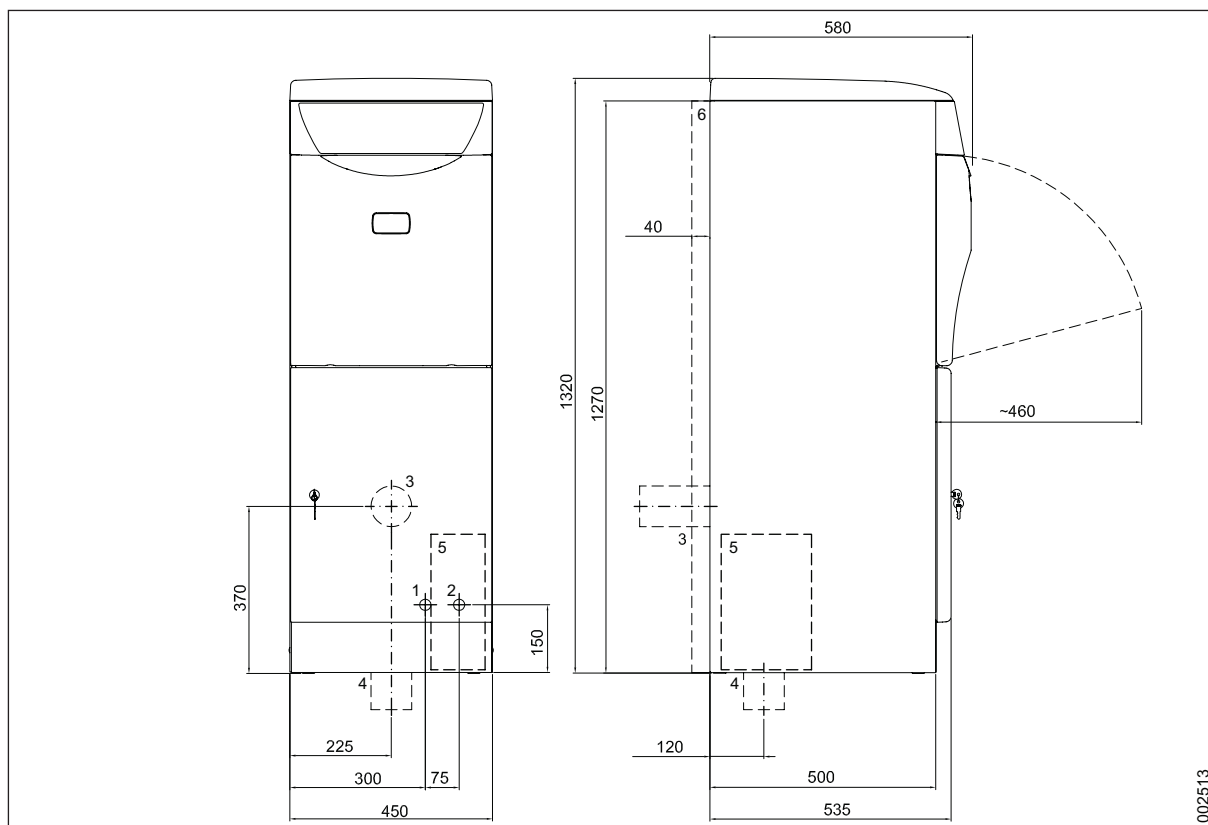

Figure 2. Scale drawing

- | | |
|------------------------------|-------------------------------|
| 1. Hot Water | 4. Waste connection, S, floor |
| 2. Cold Water | 5. Transformer |
| 3. Waste connection, P, wall | 6. Extension frame (option) |

Transformer:

- Dimensions: 300x200x210.
- Positioning: The transformer can be moved, see “Connecting electrical power”.

2.3.2 Freestanding model wall-mounted

Scale drawings apply to the FD1800 and FD1810 models.

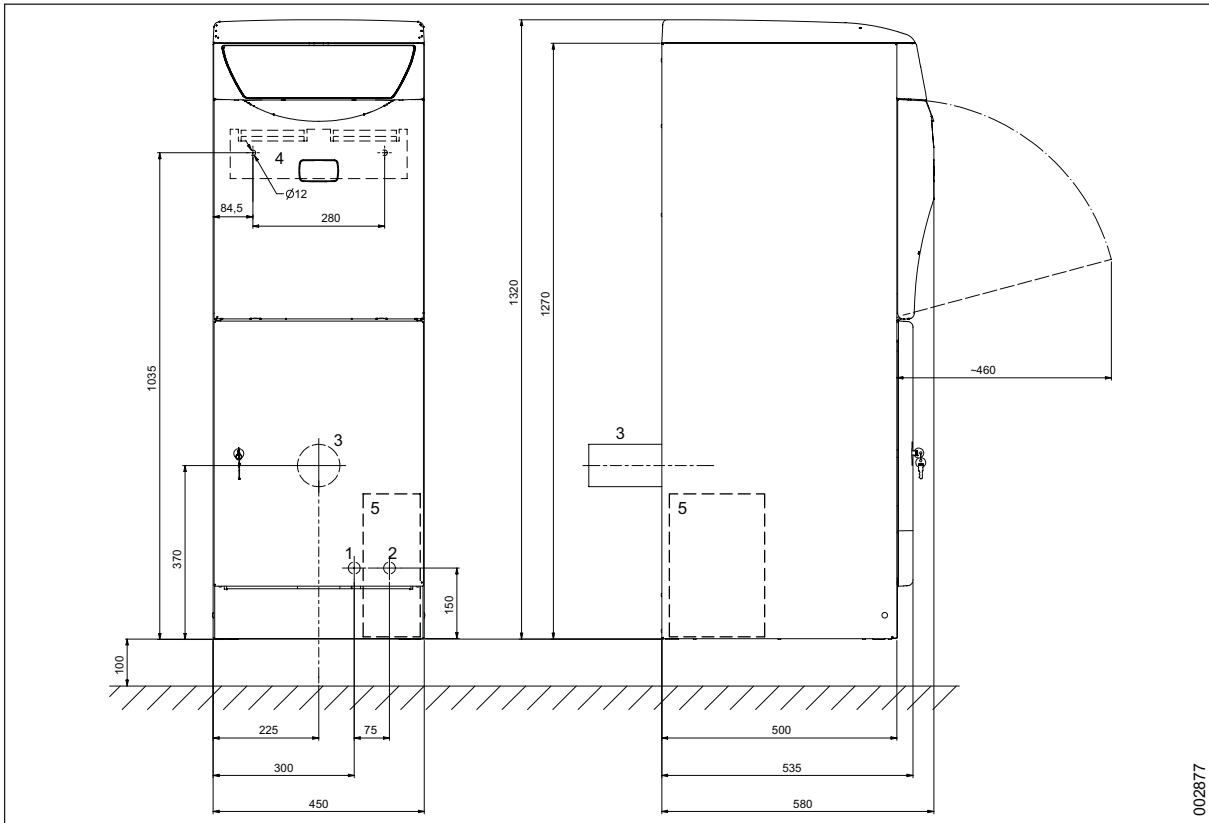

Figure 3. Scale drawing

- | | |
|---------------------------------|-----------------|
| 1. Hot Water | 4. Wall bracket |
| 2. Cold Water | 5. Transformer |
| 3. Waste connection, P,
wall | |

Transformer:

- Dimensions: 300x200x210.
- Positioning: The transformer can be moved, see “Connecting electrical power”.

2.3.3 Under-bench model

Scale drawings apply to the FD1805 model.

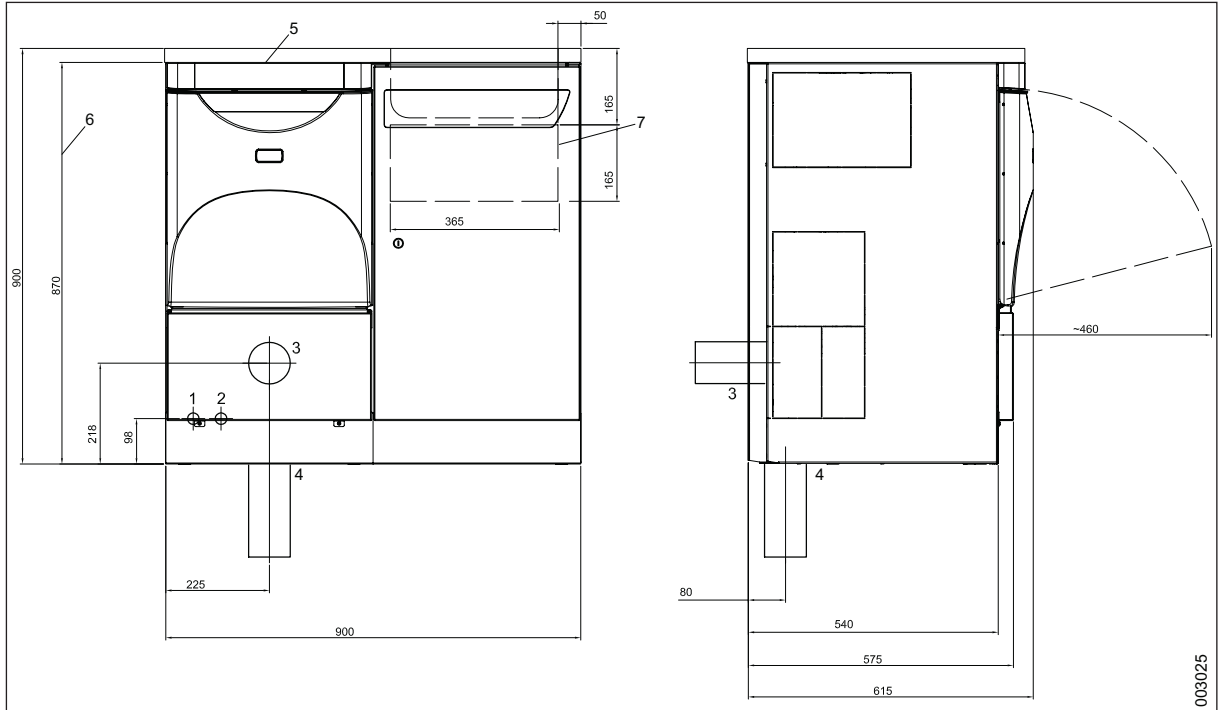

Figure 4. Scale drawing

- | | |
|----------------------------------|---|
| 1. Hot Water | 5. Protection sheet*
(option) |
| 2. Cold Water | 6. Without worktop |
| 3. Waste connection, P,
wall | 7. Connections to
optional worktop** |
| 4. Waste connection, S,
floor | |

* Protection sheet must be used if the machine is installed under a bench or similar.

** Area for water and waste connections for optional worktop with sink.

2.4 Assembly

2.4.1 Freestanding model placed next to wall

Install the machine as follows:

1. Measure out and drill the holes for the wall bracket (anti-tipper) used to secure the machine to the wall.
2. Install the water trap to the waste outlet:
 - The trap can be connected towards the rear (P-trap) or downwards (S-trap).
 - The pipe diameter is 90 or 110 mm and should be able to handle 1 liter per second.

Note!

Install the hose from the ventilator (option).

3. Position the machine in place.
4. Level the machine:
 - Use a spirit level held vertically against the side of the machine.
 - If necessary, adjust with the adjustable feet at the front of the machine.
5. Secure the machine:
 - Fix the wall bracket (anti-tipper) and attach the machine to the wall.
 - Use suitable screws and washers for the material of the wall.

2.4.2 Freestanding model wall-mounted

Install the machine as follows:

1. Drill the holes for the wall bracket in accordance with the hole pattern.
2. Drill the hole for attachment in the bottom frame.
3. Fix the wall bracket (A) to the wall (B) with screws.

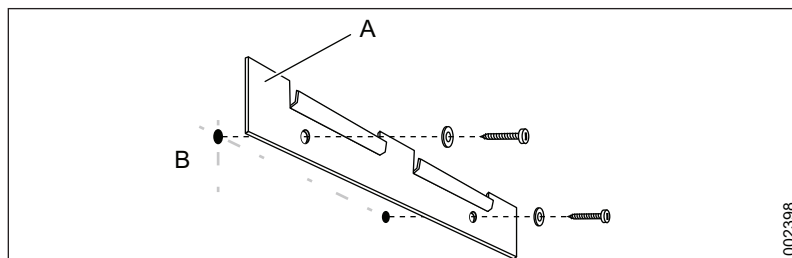

Figure 5. Installation of the wall bracket

4. Lift the machine and hook the beam (C) on the rear of the machine onto the wall bracket.

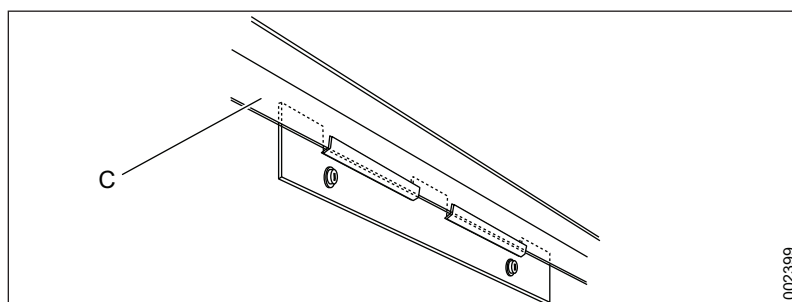

Figure 6. Hooking the machine

5. Check that the machine is vertical by putting a spirit level on one of the sides of the machine.
6. Fix the bottom frame to the wall with screws.
7. Install the water trap to the waste outlet:
 - Water trap connects from the rear (P-lock).
 - The pipe diameter is 90 or 110 mm and should be able to handle 1 liter per second.

Note!

Install the hose from the ventilator (option).

2.4.3 Under-bench model

Install the machine as follows:

1. Install the water trap to the waste outlet:
 - The trap can be connected towards the rear (P-trap) or downwards (S-trap).
 - The pipe diameter is 90 or 110 mm and should be able to handle 1 liter per second.

Note!

Install the hose from the ventilator (option).

2. Position the machine in place.
3. Level the machine:
 - Use a spirit level held vertically on the side of the machine.
 - If necessary, adjust with the adjustable feet at the front of the machine.

2.4.4 Trap and ventilator

The illustration below shows an example of fitting a water trap and ventilator. The example shows the free-standing model with the P-lock.

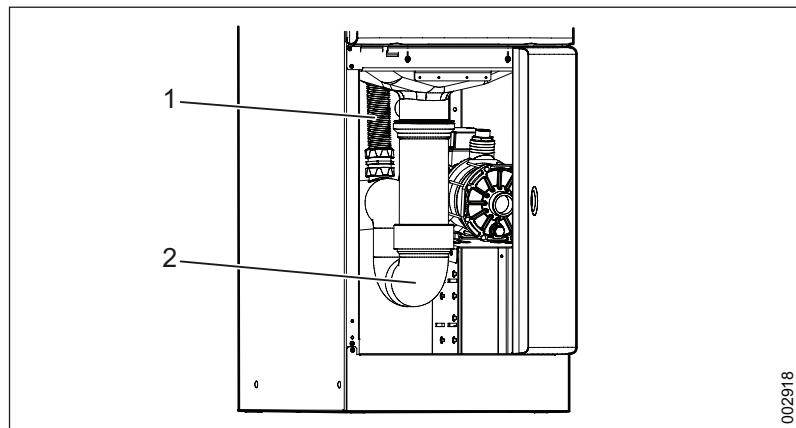

Figure 7. Example of how to fit a water trap and ventilator

1. Attached pipe from ventilator (option)
2. Attached trap

2.4.5 Sealing requirements for under-bench model

The following applies to the under-bench model FD1805.

If the outside of the machine is in contact with surrounding surfaces, the machine must be waterproofed against these surfaces to prevent water from leaking into the machine. This applies to the machine's top side (A), side panels (B) and back side (C).

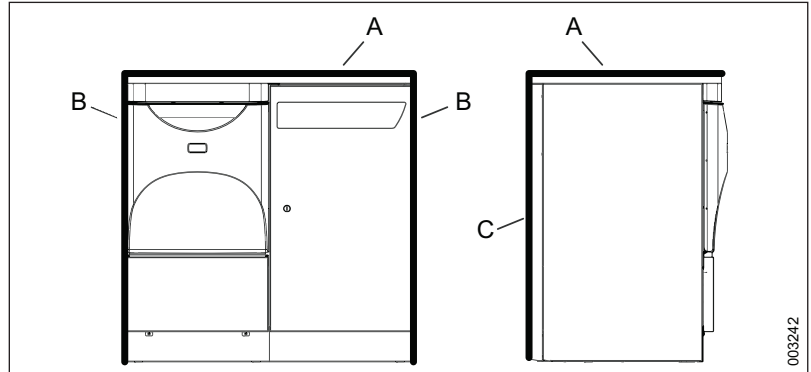

Figure 8. Surfaces with sealing requirements

2.5 Water connections

2.5.1 General requirements

The pipes must be fitted with an approved 1/2" shutoff valve.

Water connections should meet the requirements according to the table below.

	Cold water (Blue)	Warm water (Red)
Connection	15 mm (1/2")	15 mm (1/2")
Pressure	100 - 800 kPa	100 - 800 kPa
Flow rate	20 l/min at 400 kPa pressure	20 l/min at 400 kPa pressure
Temperature	At least 2°C, but less than 20°C	45 – 60°C

2.5.2 Requirements for KIWA certified installations

Use KIWA approved check valves from Arjo (A) between the water connections (B) and the machine water hoses (C).

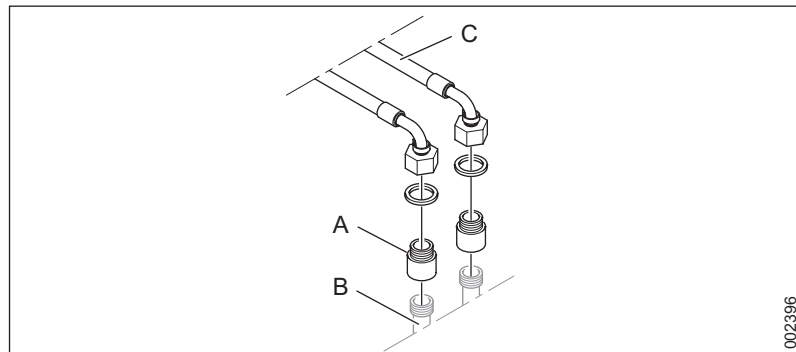

Figure 9. Installation of check valves

2.5.3 Requirements for backflow prevention installations

Backflow prevention devices are to be added during bath installation. The backflow prevention device is a Dual Check Valve – part number RMC7186.2 which is made of chrome and is Australian Watermarked.

2.5.4 Connect water

Connect the water as follows:

1. Check that the requirements for pipes and water connections are met.
2. Fit the Dual Check Valves at the water taps.
3. Connect the water.
4. For KIWA certified installations, check that the check valves are attached correctly.
5. Seal all connections with PTFE tape.

2.6 Electrical connections

2.6.1 Positioning the transformer

Placement alternatives:

- The transformer for freestanding models can be moved:
 - to the opposite side of the machine if so required due to water connections. Ensure that the transformer does not encroach on the area intended for detergents.
 - and is assembled separately from the machine. Hang up and fix the transformer on a suitable wall.
- The transformer for the under-bench model must be assembled separately from the machine. Hang up and fix the transformer on a suitable wall.

The illustration below shows alternative positioning (A) for the transformer for freestanding models.

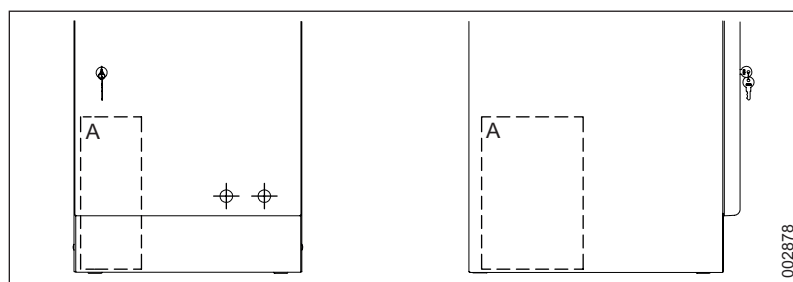

Figure 10. Alternative placement of the transformer

2.6.2 Connect electricity

Carry out the electrical installation as follows:

- Install the machine in accordance with installation category CAT II.
- Make a notch for electrical cables on the side of the machine.
- Fit the supplied cable bushing and pull the cables through.
- Connect the machine to a separate isolator switch approved to local standards, which must be mounted on the wall close to the machine.
- Connect to the protective grounding and to the supply voltage stated on the type plate. Check that the connection has suitable overcurrent protection. The correct fuse rating is stated on the type plate.
- All cables must be classified for at least 90°C.

2.6.3 Coupling alternative

2.6.3.1 Connection diagram

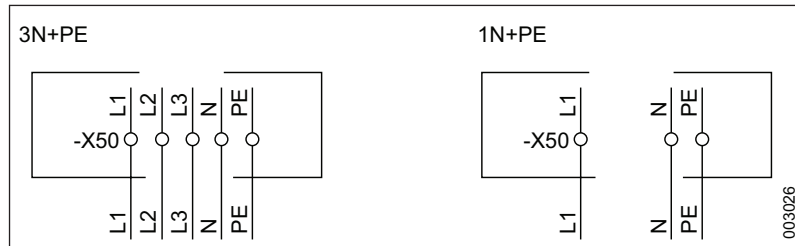

Figure 11. Electrical connection

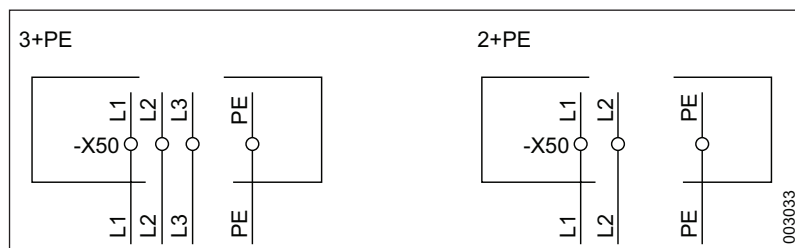

Figure 12. Electrical connection

2.6.3.2 FD1800/FD1810

Voltage	Connection	Frequency	Fuse	Power requirement
415 V	3N+PE	50 Hz	3 × 10 A	3.75 kW
400 V	3N+PE	60 Hz	3 × 10 A	3.75 kW
400 V	3N+PE	50 Hz	3 × 10 A	3.75 kW
380 V	3N+PE	60 Hz	3 × 10 A	3.75 kW
380 V	3N+PE	50 Hz	3 × 10 A	3.75 kW
240 V	3+PE	60 Hz	2 × 15 A	3.75 kW
240 V	2+PE (TN)	60 Hz	2 × 15 A	3.0 kW
240 V	1N+PE (TN)	50 Hz	1 × 16 A	3.0 kW
230 V	1N+PE (TN)	60 Hz	1 × 16 A	3.0 kW
230 V	1N+PE (TN)	50 Hz	1 × 16 A	3.0 kW
230 V	3+PE	50 Hz	3 × 16 A	3.75 kW
208 V	3+PE	60 Hz	3 × 15 A	3.75 kW
208 V	2+PE (TN)	60 Hz	2 × 15 A	3.0 kW
200 V	3+PE	60 Hz	3 × 16 A	3.75 kW
200 V	3+PE	50 Hz	3 × 16 A	3.75 kW
200 V	2+PE (TN)	60 Hz	2 × 16 A	3.0 kW
200 V	2+PE (TN)	50 Hz	2 × 16 A	3.0 kW

2.6.3.3 FD1805

Voltage	Connection	Frequency	Fuse	Power requirement
400 V	3N+PE	60 Hz	3 × 10 A	3.75 kW
400 V	3N+PE	50 Hz	3 × 10 A	3.75 kW
380 V	3N+PE	60 Hz	3 × 10 A	3.75 kW
380 V	3N+PE	50 Hz	3 × 10 A	3.75 kW
230 V	1N+PE (TN)	60 Hz	1 × 16 A	3.0 kW
230 V	1N+PE (TN)	50 Hz	1 × 16 A	3.0 kW
230 V	3+PE	50 Hz	3 × 16 A	3.75 kW

Operates within MAINS supply voltage fluctuations up to $\pm 10\%$ of the nominal voltage.

3 INSTALLATION OF OPTIONS

3.1 Printer (FD1800/1810)

3.1.1 Connection

1. Switch off the power to the machine.
2. Take the top panel off the machine.

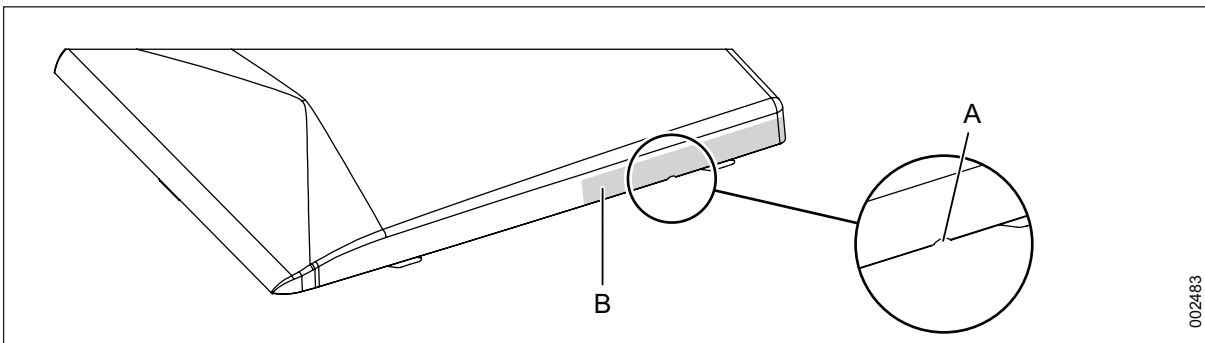

Figure 13. Placement of the opening in the top panel

3. Make an opening in the top panel (A) for the printer cable.
 - Use a file or some other suitable tool.
 - Make an opening within the area (B), which applies to both the left and right side of the top panel. The area is 175 mm in length.

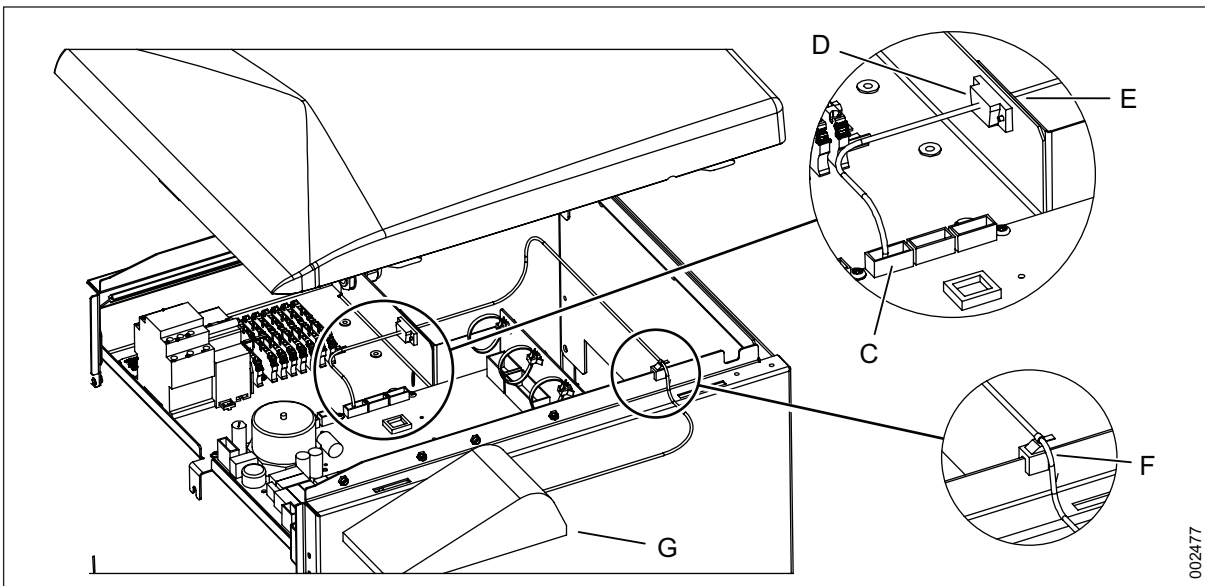

Figure 14. Connecting cables

4. Connect the interface cable (501140700):
 - Connect one end to -X25 to the PCB card (C).
 - Fix one end to the slit (D) with two D-sub screws (501140600).

5. Connect the printer cable:
 - Connect one end to the interface cable (E).
 - Attach the cable bracket (6001003001) to the metal under the opening in the top panel (F), and attach the printer cable.
6. Replace the top panel.
7. Position the printer (G) in a suitable position, connect the power to the printer, and turn it on.
8. Connect the machine to the power.

3.1.2 Configuration

The printer is factory configured and no additional installations need to be done. Where necessary, see the “Technical manual” for information regarding standard settings.

3.1.3 Test and verification

When the machine is turned on it recognizes the printer which starts to print.

To verify the installation, perform a dummy run and check that the printout looks good. How the printout can look is shown in the “User manual”.

4 INSPECTING THE INSTALLATION

4.1 When the work is complete, check that

- all parts have been installed according to the installation manual.
- all screws have been properly tightened.
- there are no sharp edges on any parts that may come into contact with people.
- all hoses, pipes and connections are intact and free from defects.
- all the functions of the machine are working properly. Adjust if necessary.

Carry out an Installation Qualification, an Operating Qualification, and a Performance Qualification according to ISO 15883 before putting the machine into service.



Incorrect use may result in damage to objects and personal injury.

4.2 Function check



WARNING!

Conduct a ground continuity test before the function check and document the result.

- Check that the flusher-disinfector is connected to the correct supply voltage and that it is protected by a fuse of the correct rating as shown on the type plate.
- Open the water valves and close the isolator switch. Check that all lights on the panel light up and that the buzzer sounds. The display then shows the current program version, followed by the preselected program.
- Check that the temperature of the incoming water is correct. The temperature must be in the range 45 – 60°C for hot water and not less than 2°C for cold water.
- Start a program with the machine empty and check that:
 - yellow light flashes for 6 seconds.
 - yellow light on  comes on.
 - the temperature rises continuously until the cooling phase begins.
 - the heating-up time does not exceed about 10 minutes.
 - the temperature reaches at least 89°C.
 - the green light at  lights up and the display shows U7 (hot goods).
 - open the door and check the max temperature in the display.
- The machine has a lime descaler system. Consult the “Technical manual” regarding how to check and adjust descaler use.
- Check that there are no water leaks. Tighten connections and pipe couplings.
- Check that the ventilator (option) starts and that the hoses are connected.

4.3 Control panel

4.3.1 FD1800/FD1805

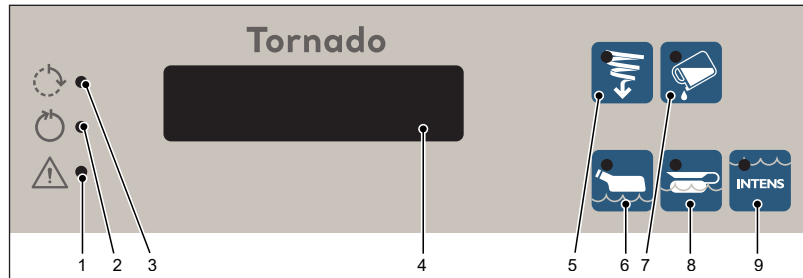

Figure 15. Control panel

- | | |
|----------------------------|----------------------|
| 1. Red: Error indication | 6. Economy program |
| 2. Green: Process complete | 7. Detergent* |
| 3. Yellow: Process running | 8. Normal program |
| 4. Display | 9. Intensive program |
| 5. Rim flushing | |
- * Option

4.3.2 FD1810

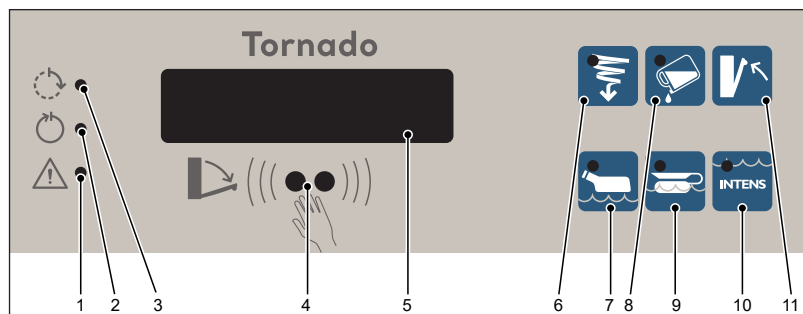

Figure 16. Control panel

- | | |
|----------------------------|---------------------------|
| 1. Red: Error indication | 7. Economy program |
| 2. Green: Process complete | 8. Detergent* |
| 3. Yellow: Process running | 9. Normal program |
| 4. IR sensor* | 10. Intensive program |
| 5. Display | 11. Door closing/opening* |
| 6. Rim flushing | |
- * Option

5 TECHNICAL DATA

5.1 Connections

	Connection	Connection requirements	Flow requirements
Cold water (CW)	15 mm (G½")	100 – 800 kPa (1 – 8bar)	20 l/min
Hot water (HW)	15 mm (G½")	100 – 800 kPa (1 – 8bar)	20 l/min
Drain (D)	Ø 90 mm or Ø 110 mm	N/A	Top 1 l/sec

5.2 Environmental requirements

Room temperature	5 – 40°C (41 – 104°F)
Air humidity	< 80 % at 31°C (87°F)
Max. surface temperature	40°C (104°F)

5.3 Water consumption

Economy program	11 liters ± 10%*
Normal program	18 liters ± 10%
Intensive program	25 liters ± 10%

5.4 Exterior dimensions

	FD1800, FD1810	FD1805
Model	Freestanding	Under-bench
Width	450 mm (17" 11/16)	900 mm (35" 7/16)
Depth	580 mm (22" 3/4)	620 mm (24" 1/2)
Height	1320 mm (51" 7/8)	Without worktop: <ul style="list-style-type: none"> • 870 mm (34" 3/16) With worktop (option): <ul style="list-style-type: none"> • 900 mm (35" 7/16)

5.5 Weight

	FD1800, FD1810	FD1805
Model	Freestanding	Under-bench
Weight	100 kg (220 lb)	120 kg (265 lb)

5.6 Protection class

	FD1800, FD1810	FD1805
Pollution Degree	2	2
Overvoltage category	II	II
Protection class	IP22 (standard) IP24 (option)	IP21
Max altitude*	2000m above sea level	2000m above sea level

* Maximum height above sea level to use the machine.

5.7 Sound level

5.7.1 Estimated sound level

Calculated sound power level L_w for the test object, dB ref 1 pW, is shown in the tables below.

The sound output level is reported as the linear octave band values and as co-weighted, A-weighted sound output level, both equivalent L_{wA} and maximum L_{wAFmax} .

Octave band frequency (Hz)	Sound output level
125	57
250	64
500	57
1000	55
2000	53
4000	50
8000	48

A-weight level.	Sound output level
L_{wA}	61
L_{wAFmax}	75

5.7.2 Example

The calculated sound power level implies different sound levels L_{pA} in different types of space. With larger room volumes, the sound level decreases slightly and with smaller room volumes it increases slightly.

The table below shows examples of what sound level to expect in practice. The room types used in the example are:

- **Hard sound:** All surfaces of tile, plaster, concrete or similar, i.e. no sound absorbents and no furniture.
- **Normally-damped:** Some sound absorption in the form of furniture and textiles.
- **Dampened:** Full-cover ceiling absorbent and some furnishing with tables, chairs and textiles.

Calculated sound level L_{pA} in a 70 m³ room, dB ref 20 µPa.

Type of room	Operator position*	3 meters from the machine
Hard sound	60/60	60/60
Normally-damped	56/56	55/55
Dampened	53/53	51/51

* The term operator position means 1 m from the machine and 1.5 m above the floor.

6 WATER QUALITY



WARNING!

It is the customer's responsibility to supply the washer-disinfector with water of the right quality.

The quality of the water used in all stages of cleaning is important for good cleaning results.

6.1 Requirements

The water used in each stage must be compatible with:

- The material that the machine is made of.
- The chemicals used in the process.
- Process requirements for the various stages of the process

6.2 Main factors

The main factors for good water quality are:

Hardness: High hardness will cause limescale deposits in the washer-disinfector, leading to poor cleaning results.

Ionic contaminants: A high concentration of ionic contaminants may cause corrosion and pitting on stainless steel. Heavy metals such as iron, manganese or copper cause instruments to tarnish.

Microbial contaminants: Goods to be washed are treated for microorganisms and their residual products, which may cause fever-like symptoms if they get into the human body. Use water that does not increase the biological load.

Sanitary chemicals: High concentrations of, and high exposure to, sanitary chemicals may cause corrosion and pitting on stainless steel.

6.3 Recommendation

- Arjo recommends that water used in the pre-rinsing, washing and final rinsing phases should be of drinking quality in accordance with the guidelines.
- Recommended water quality is drinking water with max 5°dH.
- Detailed information about acceptable water quality can be found in "Guidelines for Drinking Water Quality, published by WHO.

6.4 Local standard

Follow local standards if they are stricter than Arjo's recommendations. Especially when treated water is used for the final washing/disinfection phase.

Additional advice should also be obtained from the manufacturers of chemical and medical equipment.

6.5 Local standard, typical specification

A typical specification for treated water is:

pH	5.5 to 8
Conductivity	<30 $\mu\text{s}\cdot\text{cm}^{-1}$
TDS	<40 mg/l
Maximum hardness	<50 mg/l
Chlorine	<10 mg/l
Heavy metals	<10 mg/l
Phosphates	<0.2 mg/l as P_2O_5
Silicates	<0.2 mg/l as SiO_2
Endotoxins	<0.25 EU/ml
Total number of micro-organisms	<100 per 100 ml

7 END OF LIFE DISPOSAL

Equipment that has electrical and electronic components should be disassembled and recycled per Waste of Electrical and Electronic Equipment (WEEE) or in accordance with local or national regulation.

Disinfection liquids – if you have extra liquid, it's safe to pour it down the drain with running water. These products are water soluble and usually mixed with water when used for cleaning, your municipality will treat these cleaners the same way they would if you used them for cleaning.

The packaging containers should be recycled according to the national or local regulations.



WARNING!

The product may be contaminated and has to be disinfected before recycling.

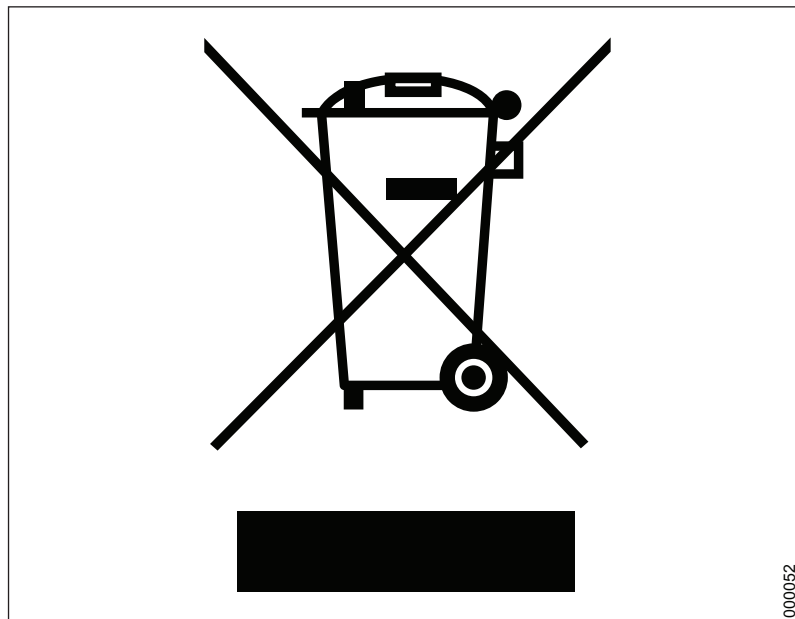

Figure 17. Recycling symbol

Intentionally left blank

Intentionally left blank

AUSTRALIA

Arjo Australia
Building B, Level 3
11 Talavera Road
Macquarie Park, NSW, 2113,
Australia
Phone: 1800 072 040

BELGIQUE / BELGIË

Arjo Belgium
Evenbroekveld 16
9420 Erpe-Mere
Phone: +32 (0) 53 60 73 80
Fax: +32 (0) 53 60 73 81
E-mail: info.belgium@arjo.com

BRASIL

Arjo Brasil Equipamentos Médicos Ltda
Rua Marina Ciufuli Zanfelice, 329 PB02
Galpão - Lapa
São Paulo – SP – Brasil
CEP: 05040-000
Phone: 55-11-3588-5088
E-mail: vendas.latam@arjo.com
E-mail: servicios.latam@arjo.com

CANADA

Arjo Canada Inc.
90 Matheson Boulevard West
Suite 350
CA-MISSISSAUGA, ON, L5R 3R3
Tel/Tél: +1 (905) 238-7880
Free: +1 (800) 665-4831
Fax: +1 (905) 238-7881
E-mail: info.canada@arjo.com

ČESKÁ REPUBLIKA

Arjo Czech Republic s.r.o.
Na Strži 1702/65
140 00 Praha
Czech Republic
Phone No: +420225092307
E-mail: info.cz@arjo.com

DANMARK

Arjo A/S
Vassingerødvej 52
DK-3540 LYNGE
Tel: +45 49 13 84 86
Fax: +45 49 13 84 87
E-mail: dk_kundeservice@arjo.com

DEUTSCHLAND

Arjo GmbH
Peter-Sander-Strasse 10
DE-55252 MAINZ-KASTEL
Tel: +49 (0) 6134 186 0
Fax: +49 (0) 6134 186 160
E-mail: info-de@arjo.com

ESPAÑA

ARJO IBERIA S.L.
Poligono Can Salvatella
c/ Cabanyes 1-7
08210 Barberà del Valles
Barcelona - Spain
Telefono 1: +34 900 921 850
Telefono 2: +34 931 315 999

FRANCE

Arjo SAS
2 Avenue Alcide de Gasperi
CS 70133
FR-59436 RONCQ CEDEX
Tél: +33 (0) 3 20 28 13 13
Fax: +33 (0) 3 20 28 13 14
E-mail: info.france@arjo.com

HONG KONG

Arjo Hong Kong Limited
Room 411-414, 4/F, Manhattan Centre,
8 Kwai Cheong Road, Kwai Chung, N.T.,
HONG KONG
Tel: +852 2960 7600
Fax: +852 2960 1711

ITALIA

Arjo Italia S.p.A.
Via Giacomo Peroni 400-402
IT-00131 ROMA
Tel: +39 (0) 6 87426211
Fax: +39 (0) 6 87426222
E-mail: Italy.promo@arjo.com

MIDDLE EAST

Arjo Middle East FZ-LLC
Office 908, 9th Floor,
HQ Building, North Tower,
Dubai Science Park,
Al Barsha South
P.O. Box 11488, Dubai,
United Arab Emirates
Direct +971 487 48053
Fax +971 487 48072
Email: Info.ME@arjo.com

NEDERLAND

Arjo Nederland BV
Biezenwei 21
4004 MB TIEL
Postbus 6116
4000 HC TIEL
Tel: +31 (0) 344 64 08 00
Fax: +31 (0) 344 64 08 85
E-mail: info.nl@arjo.com

NEW ZEALAND

Arjo Ltd
34 Vestey Drive
Mount Wellington
NZ-AUCKLAND 1060
Tel: +64 (0) 9 573 5344
Free Call: 0800 000 151
Fax: +64 (0) 9 573 5384
E-mail: nz.info@Arjo.com

NORGE

Arjo Norway AS
Olaf Helsets vei 5
N-0694 OSLO
Tel: +47 22 08 00 50
Faks: +47 22 08 00 51
E-mail: no.kundeservice@arjo.com

ÖSTERREICH

Arjo Austria GmbH
Lemböckgasse 49 / Stiege A / 4.OG
A-1230 Wien
Tel: +43 1 8 66 56
Fax: +43 1 866 56 7000

POLSKA

Arjo Polska Sp. z o.o.
ul. Ks Piotra Wawrzyniaka 2
PL-62-052 KOMORNIKI (Poznań)
Tel: +48 691 119 999
E-mail: arjo@arjo.com

PORTUGAL

Arjo em Portugal
MAQUET Portugal, Lda.
(Distribuidor Exclusivo)
Rua Poeta Bocage n.º 2 - 2G
PT-1600-233 Lisboa
Tel: +351 214 189 815
Fax: +351 214 177 413
E-mail: Portugal@arjo.com

SUISSE / SCHWEIZ

Arjo Switzerland AG
Fabrikstrasse 8
Postfach
CH-4614 HÄGENDORF
Tél/Tel: +41 (0) 61 337 97 77
Fax: +41 (0) 61 311 97 42

SUOMI

Arjo Scandinavia AB
Riihitontuntie 7 C
02200 Espoo
Finland
Puh: +358 9 6824 1260
E-mail: Asiakaspalvelu.finland@arjo.com

SVERIGE

Arjo International HQ
Hans Michelsensgatan 10
SE-211 20 MALMÖ
Tel: +46 (0) 10 494 7760
Fax: +46 (0) 10 494 7761
E-mail: kundservice@arjo.com

UNITED KINGDOM

Arjo UK and Ireland
Houghton Hall Park
Houghton Regis
UK-DUNSTABLE LU5 5XF
Tel: +44 (0) 1582 745 700
Fax: +44 (0) 1582 745 745
E-mail: sales.admin@arjo.com

USA

Arjo Inc.
2349 W Lake Street Suite 250
US-Addison, IL 60101
Tel: +1 (630) 307-2756
Free: +1 (800) 323-1245
Fax: +1 (630) 307 6195
E-mail: us.info@arjo.com

JAPAN

Arjo Japan K.K.
東京都港区虎ノ門三丁目7番8号
ランディック第2虎ノ門ビル9階
Tel: +81 (0)3-6435-6401
Fax: +81 (0)3-6435-6402
E-mail: info.japan@arjo.com

At Arjo, we believe that empowering movement within healthcare environments is essential to quality care. Our products and solutions are designed to promote a safe and dignified experience through patient handling, medical beds, personal hygiene, disinfection, diagnostics, and the prevention of pressure injuries and venous thromboembolism. With over 6500 people worldwide and 65 years caring for patients and healthcare professionals, we are committed to driving healthier outcomes for people facing mobility challenges.



ArjoHuntleigh AB
Hans Michelsensgatan 10
211 20 Malmö, Sweden
www.arjo.com

arjo

CE
2797